

# Build a Simple Mic for Next to Nothing

by  
Jack Purdum, W8TEE

I've told the story before about a really enthusiastic 13 year old who worked the Milford Field Day GOTA station. His eyes literally danced as he told his Mom what had just happened. Her response: "Yes, it seems like a wonderful hobby, but where are you going to get the thousands of dollars for the radio?" He was crestfallen. Ever since then, I've been doing whatever I can to show people that you can enjoy our hobby without spending a king's ransom.

Like many of you, I recently purchased a BITX40 from HF Signals. The 40M SSB transceiver, designed by Ashar Farhan, is conservatively rated at 7W and is fun rig to use. Recently, the company added an Si5351 DDS VFO and LCD display. The board uses SMD's, but they are soldered at the factory as are all other components from toroids to transistors. About all the individual has to do is mount the controls on a case. (All the other controls are also included in the price. About all you have to add is a case and power.) The price: \$59!

Included in that price is an electret mic cartridge and a small NO (Normally Open) pushbutton micro switch. I mention the BITX40 because it is so popular, but this article applies to anyone who wants an inexpensive mic. I saw one add for the electret cartridge on eBay *90* for \$1! The micro switch can be purchased online at 10 for \$0.75. So even if you don't share with friends, the hardware is under \$2!

## Gathering the Parts

Figure 1 shows the parts I used to build a mic for the BITX40. The barrel of the mic is a 6" long piece of 0.5" PVC I had laying around. The electret mic cartridge and the micro switch that came with the BITX40 kit are also shown. The only thing I had to buy new was the PVC end cap. My total cost:



Figure 1. Basic mic parts.

\$0.87.; your mileage may vary.

My first task was to find some 4-conductor wire to use with the cartridge and the switch. I had some 4 conductor phone extension wire left over from an abandoned phone system which seemed perfect for the task. I stripped about 3" of the outer insulation away, then stripped and tinned the four wires. Figure 2 shows soldering the two wires to the electret cartridge. If you look closely, you can see some shrink tubing on the positive wire connection. Later I did the same for the ground connection. (There are three very small traces that go from the ground connection to the outer shell of the cartridge.)

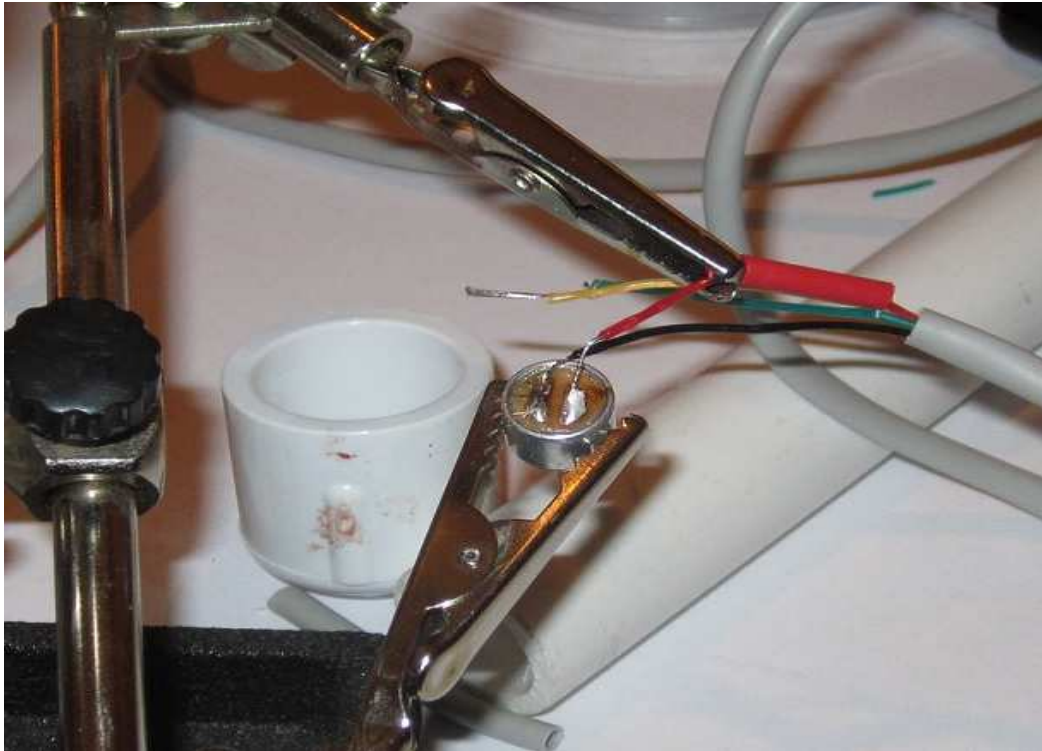

*Figure 2. Soldering the mic connections*

I dry-fitted the PVC cap in place on the 6" half-inch PVC pipe to get a feel for where I wanted to mount the PTT switch. I then used a 7/32" drill bit to drill a hole into one side of the pipe about 2" down from the end. That drill size results in a hole that is just the right size to friction-fit the switch legs in the hole.

Next, I used a 3/8" drill bit to drill a hole in the center of the PVC cap. This makes an almost perfectly-sized hole for the cartridge. I had to wiggle the drill bit just a little to enlarge the hole slightly so the mic cartridge fit snugly. Then I slid the shrink tubing that was on the leads into place and hit it with a heat gun. I then threaded the bare end of the mic cord into the PVC cap and gently pulled it until the cartridge was pulled down to the tip of the cap. I took some hot glue and put a small bead around the outside of the cap hole and quickly pushed the cartridge into the hole and let it set up.

Then I took the two remaining wires for the switch and twisted them together. I took the 6" mic barrel and slid it onto the mic cord from the bottom up to just short of where the PVC cap was now attached to the cartridge. I took a piece of string, threaded it through the switch hole and out the top of the mic barrel towards the PVC cap. I then tied the string to the switch wires and wrapped the wires and string with some tape.

The reason for the string is because it was almost impossible to pull the switch wires through the small hole I had drilled in the mic barrel for the PTT micro switch. By having the two wires twisted together and then taped to a piece of string made it pretty easy to gently pull the wires from inside the barrel, through the switch hole so I could solder them to the switch. Figure 3 gives you an idea of how all of the pieces-parts fit together.

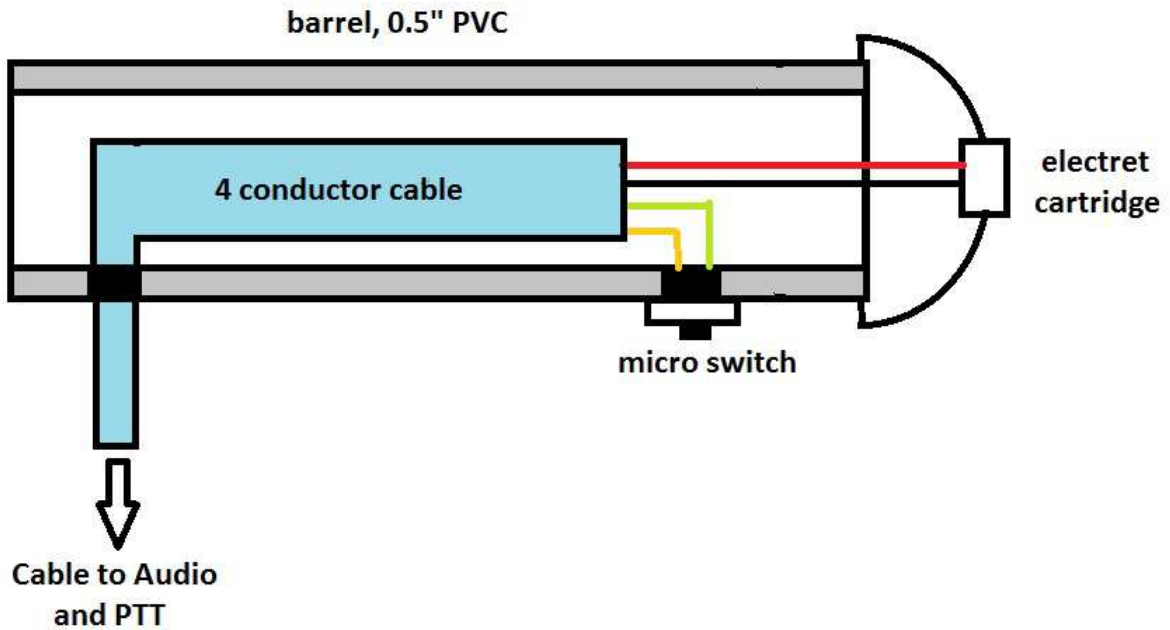

*Figure 3. Cutaway view of mic.*

I placed shrink tubing on the connections and soldered the wires to the switch. I put a dab of hot glue on the hole and pressed the switch into the hole. I had a large piece of shrink tubing that I never thought I'd find a use for, but I cut a small square hole in it, slid it up the barrel and over the micro switch, and hit it with the heat gun.

I tied a knot in the cord near the bottom of the barrel and drilled another hole near the bottom end. I threaded the cord through the hole, using the cord knot as a strain relief. I'm not sure if I am going to put something on the bottom for a base or not. For the moment, I'm using the mic without a base. The final result can be seen in Figure 4.

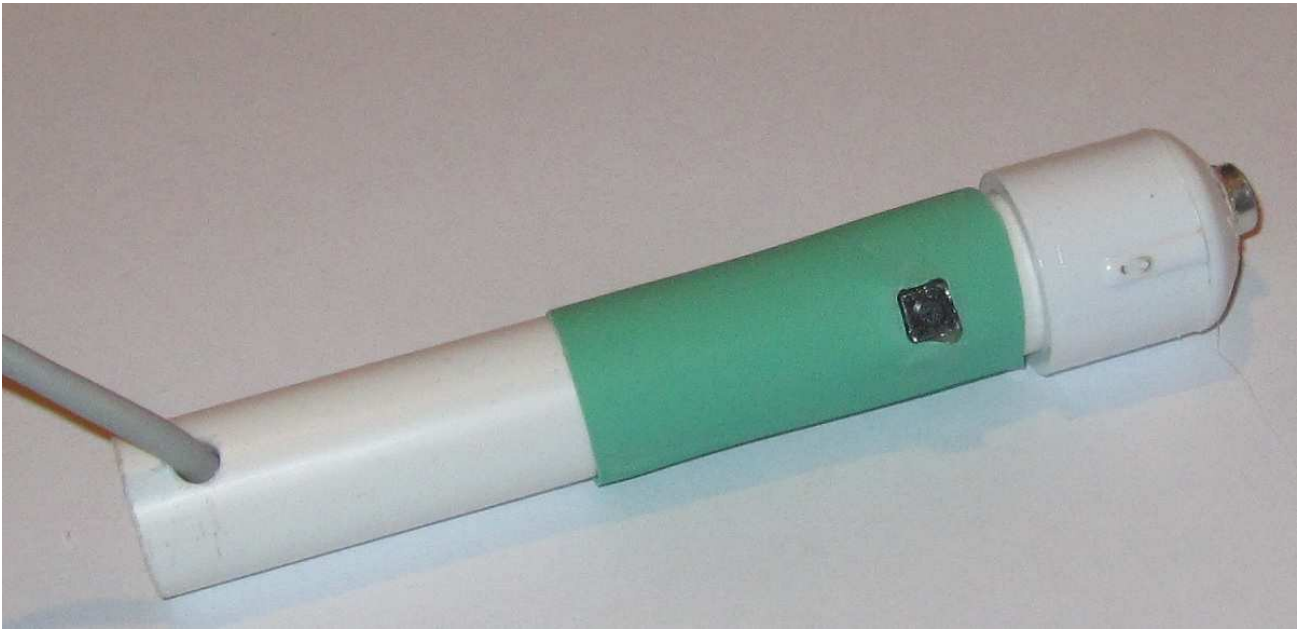

*Figure 4. My \$0.87 mic*

## **Conclusion**

The mic actually works surprisingly well. True, it's not going to win any beauty contest or design awards, but for less than a buck, it gets the job done. More importantly, it shows that you can build a decent mic on a mowing-lawns budget.